



TECHNICAL DATA

MASSES

Operating mass (incl. ROPS)	4800 kg
Operating mass (incl. Cab)	4950 kg
Module mass (front/rear)	2050 kg/2750 kg
Max. operating mass	5450 kg

COMPACTION

Static linear load	13 kg/cm
Nominal amplitude	1.7 mm
Vibration frequency	35 Hz
Centrifugal force	89 kN
Frequency	ECO: 30 Hz

TRACTION

Speed range (Dual/TC/AS)	0 -6 km/h
Tyre size (12 ply)	12.5-20
Max. theoretical gradeability	55 %
Vertical oscillation	±9°

ENGINE

Manufacturer/Model	Kubota V 3307 CR-TE4 (Stage IIIB/Tier4)
Type	Water cooled turbo Diesel
Rated power, SAE J1995	55 kW (75 hp) @ 2,200 rpm
Fuel tank capacity	117 l

ENGINE

Manufacturer/Model	Kubota V 3307 CR-TE5 (Stage V)
Type	Water cooled turbo Diesel
Rated power, SAE J1995	55 kW (75 hp) @ 2,200 rpm
Fuel tank capacity	117 l

ENGINE

Manufacturer/Model	Yanmar 4TNV98CT-PDCE (Stage V / Tier 4f)
Type	Water cooled turbo Diesel
Rated power, SAE J1995	54 kW (72 hp) @ 2,250 rpm
Fuel tank capacity	117 l

HYDRAULIC SYSTEM

Driving	Axial piston pump with variable displacement. Axial piston motor with constant displacement. Radial piston motor with constant displacement.
Vibration	Gear pump/motor with constant displacement.
Steering	Gear pump with constant displacement.
Service brake	Hydrostatic in forward and reverse lever.
Parking/ Emergency brake	Failsafe multidisc brake in rear axle and front drum motor.

Find us locally at www.dynapac.com

We reserve the right to change specifications without notice. Photos and illustrations do not always show standard versions of machines. The above information is a general description only, all information's are supplied without liability.

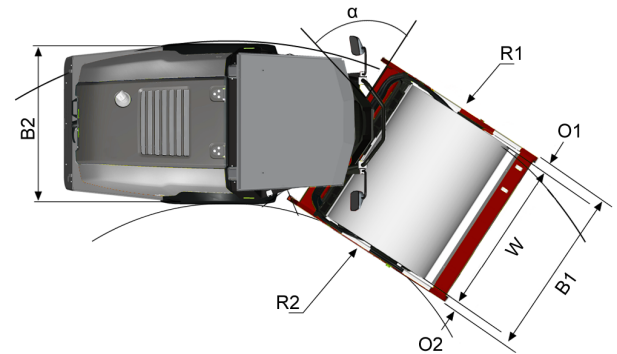
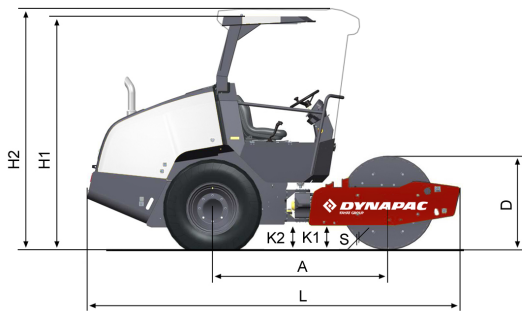

DIMENSIONS

DIMENSIONS

A. Wheelbase	1860 mm
B1. Width, front	1495 mm
B2. Width, rear	1400 mm
D. Drum diameter	1000 mm
H1. Height, with ROPS/cab	2540 mm
H2. Height, max.	2540 mm
K1. Ground clearance	260 mm
K2. Curb clearance	260 mm
L. Length	3960 mm
L1. Length	4010 mm
O1. Overhang, right	62 mm
O2. Overhang, left	62 mm
R1. Turning radius, outside	3900 mm
R2. Turning radius, inside	2460 mm
S. Drum shell thickness	22 mm
W. Drum width	1370 mm
α. Steering angle	±33°

STANDARD EQUIPMENT

- Back up alarm
- Battery switch (std)
- Brake release
- Cup and can holder
- Differential lock (limited slip)
- Drive control (right side)
- Drum drive
- ECO mode, Emergency stop
- Engine 75 hp (Tier4final)
- Engine hood (lockable)
- Fuel level display
- High mounted exhaust pipe
- Horn, Hour meter display
- Hydraulic checkpoints
- Hydraulic fluid filter ("spin-on")
- Hydraulic fluid (mineral), Interlock
- Key (starter), Lifting points
- Lifting points for jack
- Manuals (Operation & Maintenance)
- Manuals (Spare parts catalogue)
- Operator's platform (rubber mouted)
- Operator's station (fixed), Parking brake
- ROPS (fixed) or Cab with AC/heater/fan
- Seat (adjustable), Seat belt 3"
- Storage box (on platform)
- Storage for laminated manuals
- Tie down points
- Vandal cover (instrument panel)
- Warning lights (brake engine oil pressure engine oil temperature, Engine diagnostics low charge, low fuel level)

OPTIONAL EQUIPMENT

Air Conditioning /Automatic Climate Control (ACC) (Optional)

- The system contains fluorinated greenhouse gases.
- Coolant designation: HFC-134a
- Coolant weight when full: 0,62 kg
- CO₂-equivalent: 0,887 ton
- GWP: 1430